

BOSE900X

90cm, 9 Function, Built in Electric Oven

BLANCO



Model Code

BOSE900X

Description

90cm 9 Function Electric Oven

Accessories

Included Accessories:

- 1 x Baking tray
- 1 x Grill pan

Warranty

BLANCOCare™ 2 years parts & labour

Features

Benefits

Large Oven Capacity

At 129 litres, this large capacity oven will accommodate even the biggest of meals.

Triple Glazed Thermo-reflective Door

The triple layered door with thermo-reflective glass offers not only a cooler to touch surface but also increases the energy efficiency as the heat is retained within the oven.

Fully Programmable

The fully programmable touch control operation enables you to set the start and finish time of your cooking where the oven will automatically switch off when finished.

Twin Fan

With twin fan ring elements, it ensures an even cooking distribution inside the 129 litre cavity.

Specifications

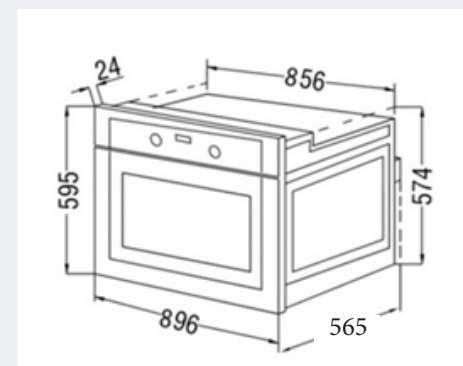

Product Dimensions:	H595 x W896 x D565 mm
Power Requirement:	220-240V – 50Hz
Electrical connection:	15 amp – cable supplied – hard wired
Oven volume:	129 litre capacity
Oven Functions:	Light, conventional, steam clean, top element, maxi grill, maxi grill with fan assist, fan assisted conventional, fan force, defrost.
Lighting:	25 W

Oven Elements:

Grill element:	2500 W
Top oven element:	1500 W
Bottom oven element:	2000 W
Fan forced element:	2500 W
Hot air fan motor:	20-25 W
Cooling fan motor:	24 W

NOTE: It is advisable to check dimensions of physical product when measuring for installation and before doing any cut outs.

*Due to continual product development the information provided is not final and may be subject to change.