

Code ESM90TSX - 90cm Multifunction Electric Oven



FEATURES

- + 7 multi-functions
- + Fan-forced / Fan Assisted multifunction cooking
- + Push Pull knob function selector
- + Telescopic Rail (x1 set)
- + Triple Glazed Door
- + Easy Removable door
- + Full inner glass door
- + Contained cavity cooling
- + Stainless Steel
- + Manufactured in 18/10 grade stainless steel
- + Under-bench or wall oven installation
- + Timer Touch Clock Function
- + Made in Italy

CAVITY COOLING SYSTEM

This oven has a contained cavity cooling system with internal cooling fan. This ensures control knobs are cool and protects surrounding cupboards. The cooling system also provides flow through oven door cooling.



FAN FORCED COOKING

For the ultimate roast or perfect batch of pastries. The element surrounding the fan delivers even heat for even cooking results, approx. 160°C - 180°C is recommended.



FAN GRILL

This function is perfect for grilling foods such as fish, without the need for turning. The door must be left closed whilst grilling and browning will occur from the top element.

HALF GRILL

Half grilling allows you to toast/brown all your favourite recipes in a smaller area.



CONVENTIONAL

This conventional cooking method involves a gentle heat from the lower and upper elements for long slow cooking. This function is perfect for cakes, casseroles and slow roasts.



THERMOWAVE FAN ASSISTED

This is the position where the heat is coming from the lower and upper heating elements. This provides very even cooking throughout the middle zones of the oven.



FAN AND BOTTOM ELEMENT

Great for pizza cooking, the fan and bottom element create the perfect cooking function for base cooked food.



OVEN LIGHT

The oven light will automatically turn on once any function is selected, helps to monitor the progress of your cooking.

POWER CONSUMPTION:

220-240V / 50HZ – 2900 W

NET WEIGHT: 58.0kg

GROSS WEIGHT: 64.0kg

OVEN VOLUME CAPACITY: 93L Gross / 84L net useable

INSTALLATION: Oven requires 15 amps and need a dedicated circuit from the socket to the main switchboard. For all installation please refer qualified technician to our product manual.

CLEANING AND MAINTENANCE

Easy clean **AAA** grade enamel interior. Clean stainless steel using only recommended stainless steel cleaning products. No abrasives, corrosive detergents, bleaches or acids not required for cleaning the oven.

PRODUCT DIMENSIONS

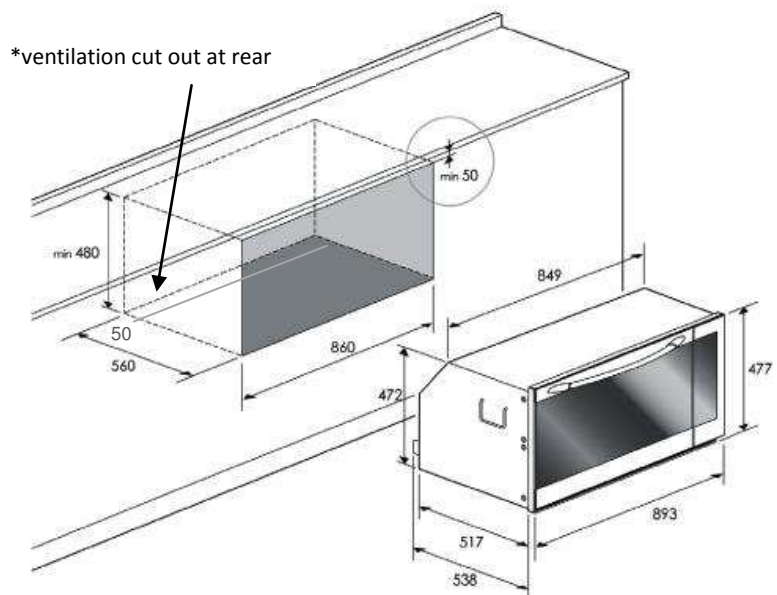

* For wall installation please refer to product manual.

