

Code EV900MSX - 90cm Multifunction Electric Oven



CONVENTIONAL

The top and bottom elements activate without the fan. This provides a traditional style of cooking suitable for slow cooking cakes and delicate pastries.



FAN GRILL

This function is perfect for fish, chicken fillets or meat cutlets. The door can be left closed whilst grilling and browning will occur from the top element.



FAN & BOTTOM ELEMENT

An ideal function for browning from the base only or browning from the bottom element of the oven.



OVEN LIGHT

The oven light will automatically turn on once any function is selected, helps to monitor the progress of your cooking.

FEATURES

- 7 multi-functions
 - + Fan-Forced
 - + Thermowave Fan Assisted
 - + Conventional
 - + Fan & bottom element
 - + Fan Grill
 - + Half Grill
 - + Oven light
- Fan-forced / Fan Assisted Convection cooking
- Contained cavity cooling with tangential fan
- Triple glazed full inner glass door
- 120 minute auto cut out timer
- Under-bench or wall oven installation
- Stainless steel / black contemporary design



FAN-FORCED COOKING

The element surrounding the fan delivers even heat for even cooking results, perfect for the ultimate roast or batch of pastries, approx. 180°C - 220°C is recommended.



THERMOWAVE FAN ASSISTED

Even baking is achieved with the top and bottom element forcing heat into the centre, whilst the fan distributes the heat evenly.



HALF GRILL

Half grilling allows you to toast / brown all your favourite recipes in a smaller area.

Ovens



bringing european quality to your home

ELECTRICAL REQUIREMENTS

Oven requires 15 amps and need a dedicated circuit from the socket to the main switchboard.

For all installation please refer qualified technician to our product manual

POWER CONSUMPTION:

220-240v – 50Hz - 2900W

WEIGHT:

64.0kg (gross) – 58.0kg (net)

OVEN VOLUME CAPACITY:

93 litres (gross) - 84 litres (net)

CLEANING & MAINTENANCE:

Easy clean AAA grade enamel interior. Clean stainless steel using only recommended cleaning products. No abrasives, corrosive detergents, bleaches or acids are not required for cleaning the oven.

PRODUCT DIMENSIONS

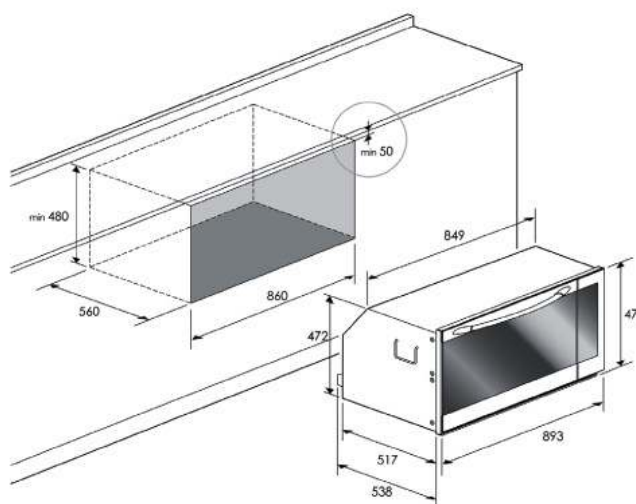

* For wall installation please refer to product manual.